

SCMPB02

16-Position Analog I/O Backpanel, Multiplexed



Description

The SCMPB02 16-channel backpanel (Figure 5) can accept any of the SCM5B analog modules in any mixture. It can be mounted on the SCMXRK-002 19-inch metal rack. The SCMPB02 has two analog buses; one for analog input and one for analog output. This two-bus configuration takes advantage of the switch controlled outputs on the input modules and the track-and-hold inputs on the output modules. A temperature sensor is mounted on each channel to provide cold junction compensation for thermocouple input modules (See Figure 6 for schematic). Field connections are terminated with four screw terminals at each module site. Up to four SCMPB02 backpanels may be daisy-chained. Use SCMXCA004-XX cable for daisy chaining and connecting to host computer.

Specifications

Operating Temperature ATEX Group II, Category 3 Relative Humidity	-40°C to +85°C -20°C to +40°C 95% non-condensing
Interface Connector: Field System	high density screw clamp, 14 AWG max 26-pin, male header connector
Address Input Logic Levels: Max Logic "0" Min Logic "1"	0.8V 2.0V
I _i Input Current, "0" or "1"	0.1µA max at 25°C 1.0µA max -25°C to +85°C
RD EN _i or WR EN _i Signal Delay from Connector P1 to Channels 1-16 Standalone (address 0-15) Expanded (address 16-63)	51ns at 25°C 64ns at -25°C to +85°C 100ns at 25°C 126ns at -25°C to +85°C

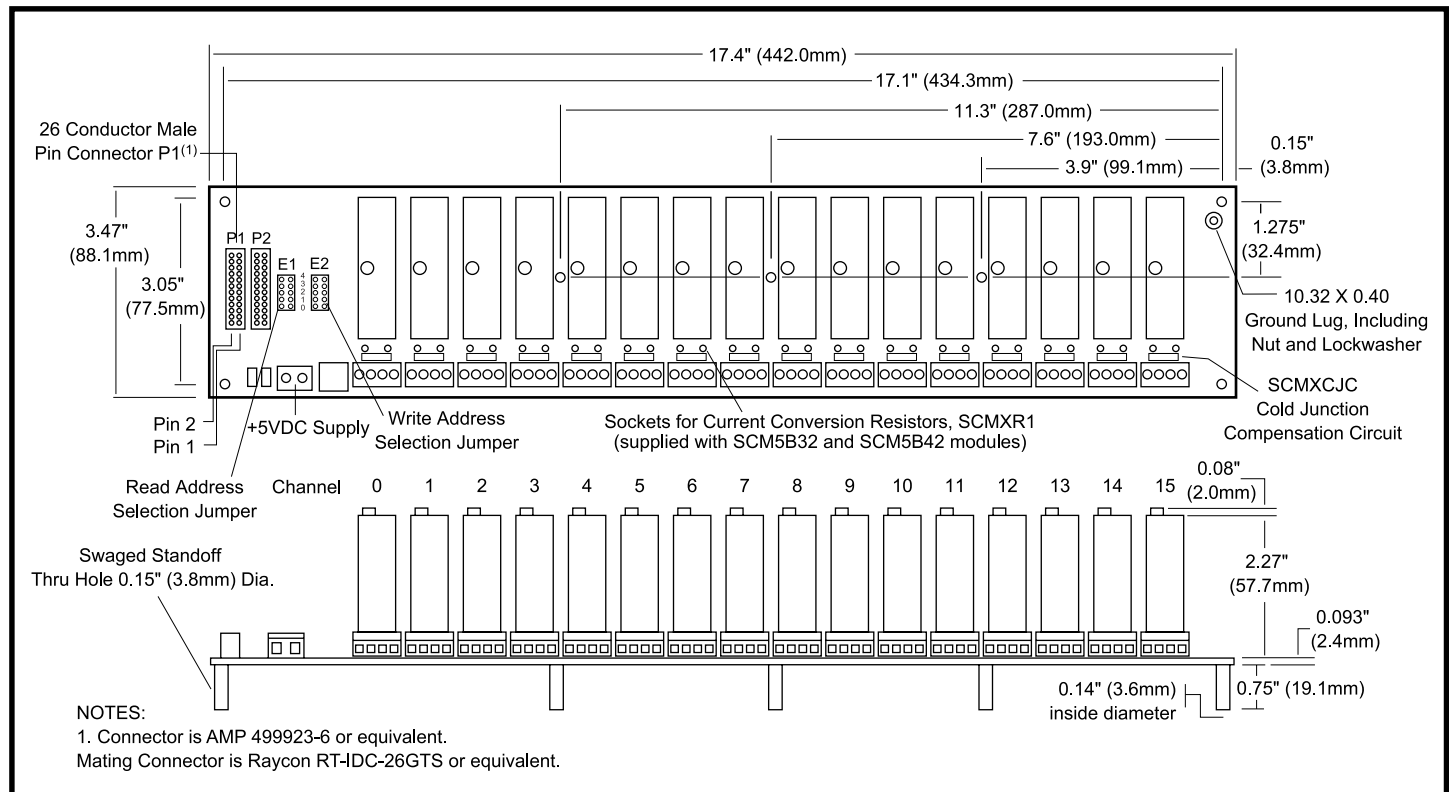
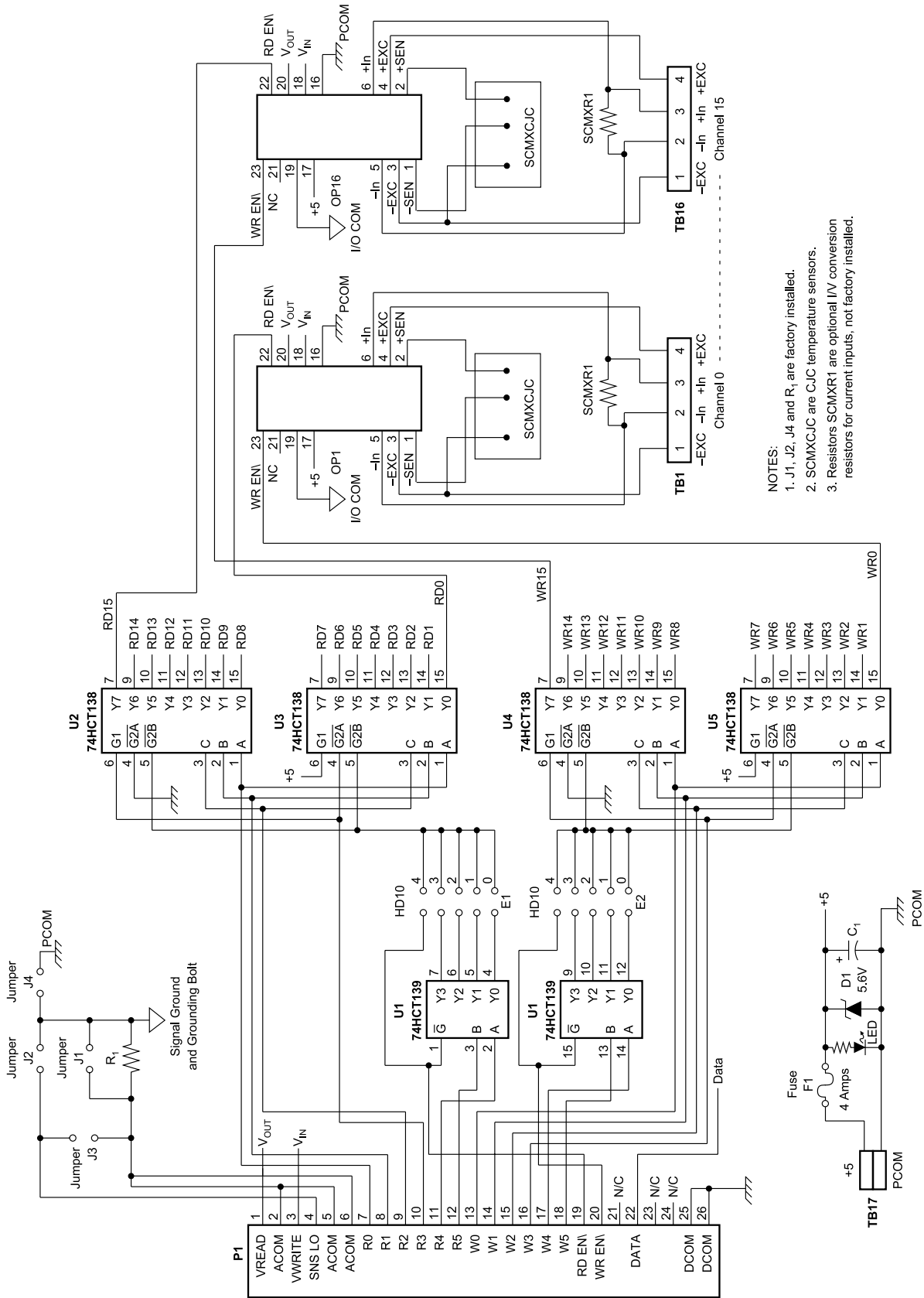

Figure 5: SCMPB02 Analog I/O Backpanel



- NOTES:
1. J1, J2, J4 and R₁ are factory installed.
 2. SCMXCJC are C/JC temperature sensors.
 3. Resistors SCMXR1 are optional I/V conversion resistors for current inputs, not factory installed.

Figure 6: SCMPB02 Schematic

Electrical

P1 Connector

The 26 pin P1 connector provides the signal interface between the SCMPB02 backpanel and the host measurement system. Two separate analog bus connections are provided; one for analog input signals and one for analog output signals. Two sets of six address lines and an enable pin allow input and output modules to be independently multiplexed onto their respective analog signal bus. R0 thru R5 and RD EN\ are used for input modules, and W0 thru W5 and WR EN\ are used for output modules.

Address Selection

The SCMPB02 backpanel has address decoding circuitry to allow multiplexing any combination of up to 16 input or output modules. Capability is also provided in the address decode circuitry to expand the system to 64 channels (four SCMPB02 backpanels) of multiplexed input or output. Jumpers on HD10 header, E1 and E2 group, select which set of 16 addresses are assigned to a particular backpanel. The E1 group assigns a set of 16 addresses for input modules, and the E2 group assigns a set of 16 addresses for output modules. The table below shows the correlation of jumper position to address range.

E1 Jumper Pos	E2 Jumper Pos	Address Range/Mode
4	4	0-15, STAND ALONE
3	3	48-63, EXPANDED
2	2	32-47, EXPANDED
1	1	16-31, EXPANDED
0	0	0-15, EXPANDED

To connect multiple SCMPB02 backpanels in this expanded configuration, use interconnect cable SCMXXA004-XX.

Power

The SCMPB02 backpanel requires external +5VDC ±5% power. The chassis mounted SCMXPRT-003 or SCMXPRT-003 power supplies have adequate capacity to power any combination of modules.

Fusing

The SCMPB02 backpanel power is fuse protected through F1. This is a Littlefuse type 252007, 7 amp fuse. Zener diode DZ1 provides extra protection by clamping the input power voltage to +5.6V. If the input supply voltage connection is reversed, this zener diode will be forward biased and fuse F1 will be blown.

Grounding

Figure 7 below details the optional ground jumper configuration available on the SCMPB02 backpanel. Jumpers J1, J2, and J4 are factory installed.

Jumper J1 connects the SIG COM shield wires (pins 2, 5, and 6) to the backpanel signal ground. This provides a ground connection between the host system and backpanel. Jumper J1 is required if output modules (SCM5B39, SCM5B49) are used, or if there is no high impedance sense input (input low of a differential or pseudo-differential system) on the host measurement system.

Jumper J2 connects the SNS LO line (pin 4) to the backpanel signal ground. If the host system has the capability, this allows measuring the SCMPB02 ground potential.

Ordering Information

Part Number	Description
SCMPB02	Standard 16-channel backpanel.
SCMPB02-1	SCMPB02 without cold junction compensation circuits. Use when cost savings is desired and thermocouple input modules SCM5B37 and SCM5B47 will not be used.
SCMPB02-2	SCMPB02 with DIN rail mounting option. The backpanel is mounted on a piece of anodized aluminum, which is captured by the SCMXXBEFE DIN rail mounting elements. The backpanel is shipped fully assembled.
SCMPB02-3	SCMPB02-1 with DIN rail mounting option. See SCMPB02 and SCMPB02-2 for details.

For proper operation of the output switch or track-and-hold circuit when using the SCMPB02/06 backpanels, a current path must exist between the host control logic power common and module I/O Common (module pin 19). This path can be established on the SCMPB02 via jumper J4. If this connection exists elsewhere in the system, jumper J4 should be removed since possible ground loops could exist. Other connections of power ground and signal ground usually occur at the A/D or D/A converter of the host measurement system. More information on grounding can be found in Application Note AN502.

If the connection of power common and SIG COM shield wires exist in the host measurement system, a resistive connection between SIG COM and the backpanel signal ground can be made via R₁. R₁ can be as large as 10K ohms; 100 ohms is a recommended value. Jumper J3 can be used to connect the SNS LO line to R₁ when this ground configuration is used.

For full protection against large electrical disturbances on the field-side of the SCM5B modules, a #10-32 ground stud is provided on the backpanel. An electrical connection between this ground stud and system ground should be provided with a large gauge wire of the shortest possible length. When this connection is made, a possible ground loop could result through the SIG COM shield wires and backpanel signal ground. If the application involves only input modules and a differential input is used by the host measurement system, J1 should be removed. Remember that J1 is required if output modules are used or if the host system does not have differential inputs.

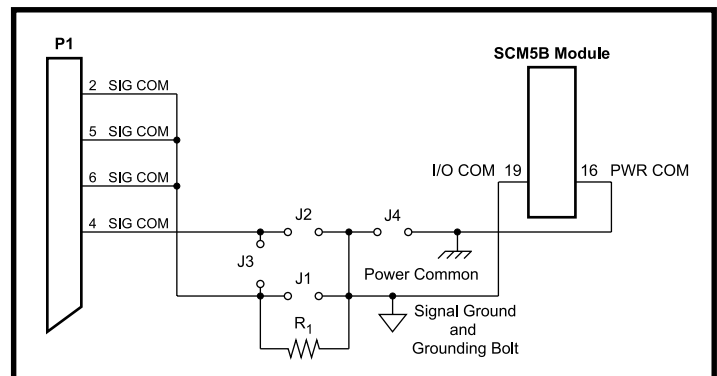

Figure 7: SCMPB02 Grounding Diagram