

SCMXEV

Analog Module Evaluation Board

Description

The SCMXEV is a single channel board with a test socket for SCM5B module evaluation (Figure 17). All signal input/output, control, and power connections are connected to terminal blocks for ease of user access. A cold junction temperature sensor circuit is included for evaluation of thermocouple modules. (See Figure 18 for schematic).

The SCMXEV is mechanically compatible with DIN rail mounting. Phoenix brand Universal Module (UM) elements may be used. The following Phoenix parts would be used to mount one SCMXEV.

- 2, UM-BEFE base elements with snap foot
- 2, UM-SE side elements
- 4, UM-VS connection pins

Two jumpers are provided for customer use. The first, J1, provides a current path between +5V Power Common (module pin 16) and I/O Common (module pin 19). A path must exist between the host control logic power common and module I/O Common for proper operation of the module output switch or track-and-hold circuit. If this connection exists elsewhere in the system, jumper J1 should be removed since possible ground loops could exist. Other connections of power ground and signal ground usually occur at the A/D or D/A converter of the host measurement system.

Jumper J2 is used in the cold junction compensation circuit. If it is installed, the compensation circuit is enabled and will provide the proper compensation voltage to correct for the thermoelectric effect at the +In and -In screw terminals. If an external simulation voltage is desired for cold junction compensation, J2

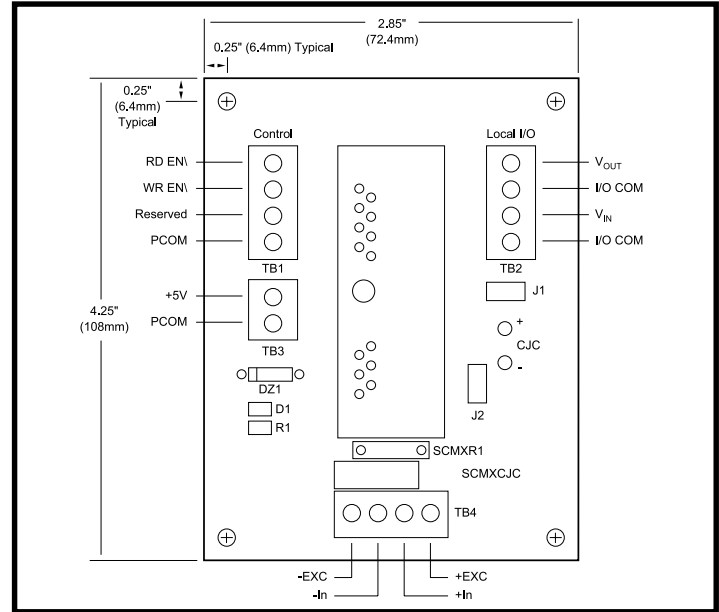
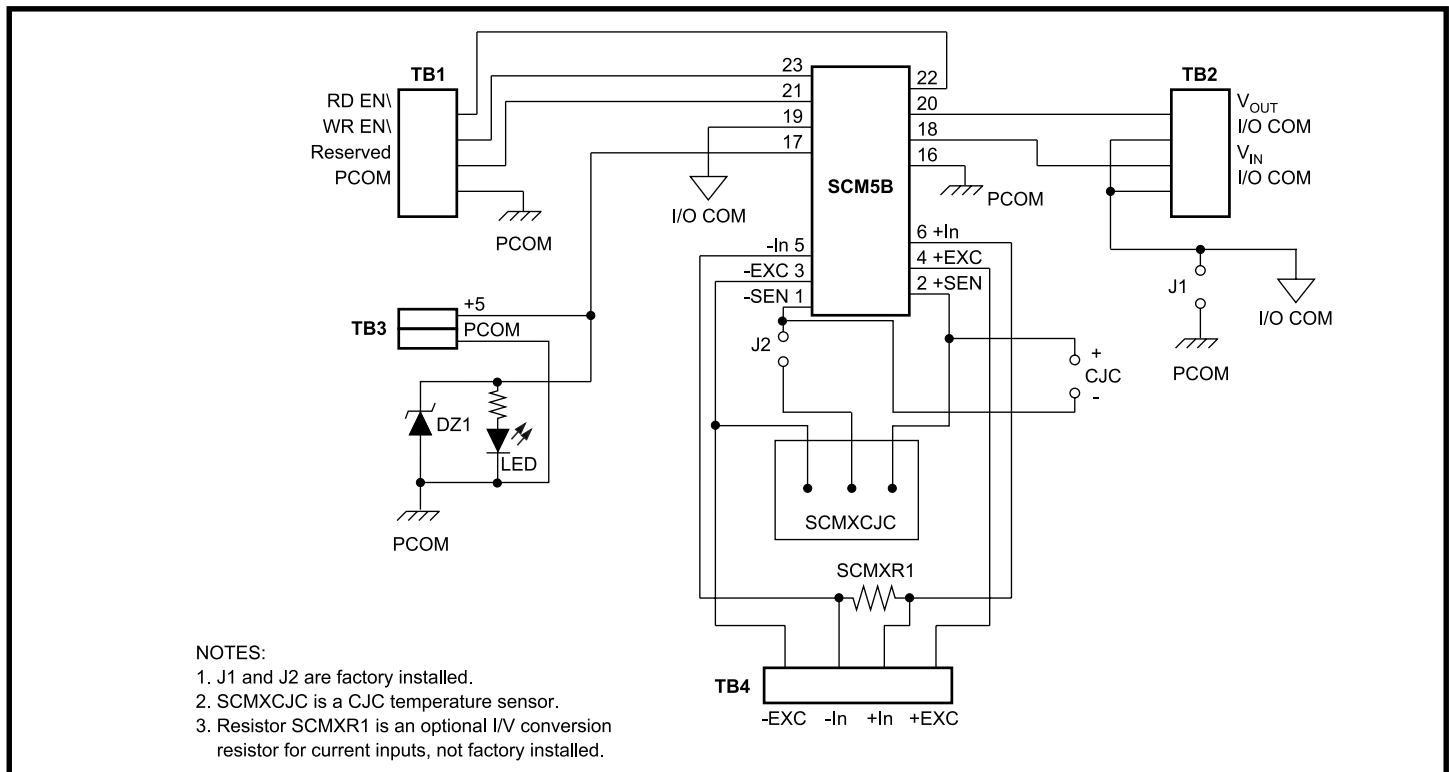

Figure 17: SCMXEV Evaluation Board Dimensions and Pin Layout

should be removed. The external voltage is applied at the sockets labeled CJC+ and CJC-. An external voltage of 510.0mV corresponds to an ambient temperature of +25 °C. The transfer function of the onboard compensation circuit is $V_{CJC} = 0.510 - 0.0025(T-25)V$.



- NOTES:
1. J1 and J2 are factory installed.
 2. SCMXCJC is a CJC temperature sensor.
 3. Resistor SCMXR1 is an optional I/V conversion resistor for current inputs, not factory installed.

Figure 18: SCMXEV Evaluation Board Schematic