

# LDM485



## Fully Isolated Limited Distance Modem, RS-232/485 Converter

### Description

The LDM485 is a compact RS-232 to RS-485 converter which features a complete electrical isolation barrier and heavy duty electrical surge protectors. These devices feature a rugged aluminum enclosure small enough to mount on the back panel of typical computer equipment, saving valuable desk and floor space. Isolation is provided by optical couplers and a DC-to-DC converter. The RS-232 connection is through male or female EIA 25-pin connectors. The RS-485 connections are made through convenient solderless screw terminals.

The LDM485 series is designed for full duplex operation over two-wire pairs. Outputs are tri-state, allowing multidropping of up to 64 units. Hardware handshake is available over two separate wire pairs. Data rates are DC to 57.6k baud. Six diagnostic LED indicators are provided (see Figure 1) for installation guidance and system troubleshooting. The RS-232 interface supports Request To Send, Clear To Send, Data Set Ready, Received Line Signal Detect, and Data Terminal Ready. A convenient null modem switch is provided for the data lines. Also, a line termination switch connects a line termination resistor and line bias resistors to the RS-485 receive lines. The RS-485 interface supports Request To Send and Clear To Send on separate wire pairs. The LDM485 may be used to convert two sets of send and receive channels by using RTS and CTS circuits as the second data channels. Data rates are the same. The units use 12VAC from a wall-mounted transformer to screw terminals 1 and 2 on the RS-485 connector. Alternately, they can use  $\pm 12$ VDC to pins 9 (+) and 10 (-) of the RS-232 connector.

### ► Features

- Complete Isolation with Optical Couplers and Power DC-to-DC Converter
- Industrial Surge Protection Devices
- Six LED Diagnostic Indicators
- 19.2K Baud at 3 Miles (5km), 57.6K Baud at 0.5 Miles (0.8 km)
- Request-To-Send, Clear-To-Send Handshake
- Tri-state Outputs for Multidrop Applications, Up to 64 Devices
- Selection of Connectors
- Wide Operating Temperature Range
- Solderless Screw Terminal Field Connections
- CE Compliant

Dataforth does not authorize or warrant its products for use in life support/critical applications.

### Specifications

Model	LDM485
Baud Rate Range	0-57.6K
Baud Rate	57.6K 38.4K 19.2K 9.6K 4.8K 1.2K-0
Distance(miles) <sup>(1)</sup>	0.5 1.0 3.0 4.0 5.0 8.0
Distance(km)	0.8 1.6 4.8 6.4 8.1 12.9
Wire Capacitance Maximum Multidrop Units	Equal to 25pf per foot and up to 32 multidrop units 64
Common Mode Isolation	Surge: 1500V Continuous: 1000V (AC input)
Differential Mode Surge Protection (9 devices)	ANSI/IEEE C37.90.1 (all RS-485 inputs and outputs)
Modes	Asynchronous 4-wire duplex, 2-wire half-duplex, 2-wire simplex
Channel Lines <sup>(2)</sup> Control Lines <sup>(2)</sup>	TD, RD, RTS, CTS RTS, CTS, DTR, DSR, RLSD
Null Modem Switch	1 (Reverses RS-232 pins 2 and 3)
RS-485 Output Drive RS-485 Input Impedance	60mA max/output 12k $\Omega$ min/input
Power	
AC operation <sup>(3)</sup>	12VAC, $\pm 10\%$ , 10W screw terms 1 & 2
DC operation	+11.5VDC to +17.0VDC at 500mA on pin 9 -11.5VDC to -17.0VDC at 100mA on pin 10

Model	LDM485
Environmental:	
Operating Temperature Range	0°C to +70°C
Storage Temperature Range	-40°C to +85°C
Relative Humidity	0-95% non-condensing
Dimensions	6.6" x 2.1" x 1.28" (167.6mm x 53.3mm x 32.5mm)
Weight	7 oz (198g) max
PT3 and PT3E	11.0 oz (312g) max
MTTF <sup>(4)</sup>	>100,000 hrs

#### NOTES:

(1) Distances reduced if multidropping more than 32 units; by 30% for 33-48 units; 50% for 49-64.

(2) TD = Transmit Data, RD = Receive Data, RTS = Request To Send, CTS = Clear To Send, DTR = Data Terminal Ready, DSR = Data Set Ready, RLSD = Received Line Signal Detect.

(3) 120VAC and 220VAC power transformers are available.

(4) Ground-benign environmental conditions (no salt atmosphere, <50°C ambient temperature).

The LDM485 conforms to EIA RS-232 and RS-485 specifications. Data Terminal Ready must be asserted by the host RS-232 port before the LDM485 can transmit data. When Data Terminal Ready is not asserted, all outputs of the LDM485 are high impedance, allowing up to 64 LDM485 units to be multidropped on a common communications cable. See Figures 1 and 3 for details.

Request To Send and Clear To Send are carried through the RS-485 port as two separate wire pairs. These may be used for full duplex flow control.

**Cable Capacitance Effects On Distances**

The distances in the specifications are for the wire sizes 18-24AWG (0.82-0.20mm<sup>2</sup>) with a maximum capacitance of 25pF/ft (82pF/m). For higher capacitance cables, decrease distance specifications for 2400 baud and above by a proportionate amount. For example, shielded cable with 50pF/ft (164pF/m) would reduce the distances by 50%. Recommended wire gauges are #18 to #24 (0.82-0.20mm<sup>2</sup>).

For baud rates of 1200 and below, distances are limited by DC voltage drop. For 2400 baud and above, distances are limited by pulse distortion. The use of low-capacitance cable can extend the distances shown. Belden 9182 and 9184 are, respectively, single and dual twisted-pair cables that are especially designed for high-speed data communications applications. With these cables the distances can be extended by 50%. However, the DC-resistance-limited distance given under 1200 baud may not be exceeded.

Cable capacitance for individually shielded wire pairs is usually given by manufacturers as capacitance between wires and capacitance from each wire to the shield. The effective transmission line capacitance is approximately the interwire capacitance plus one-half of the wire-to-shield capacitance.

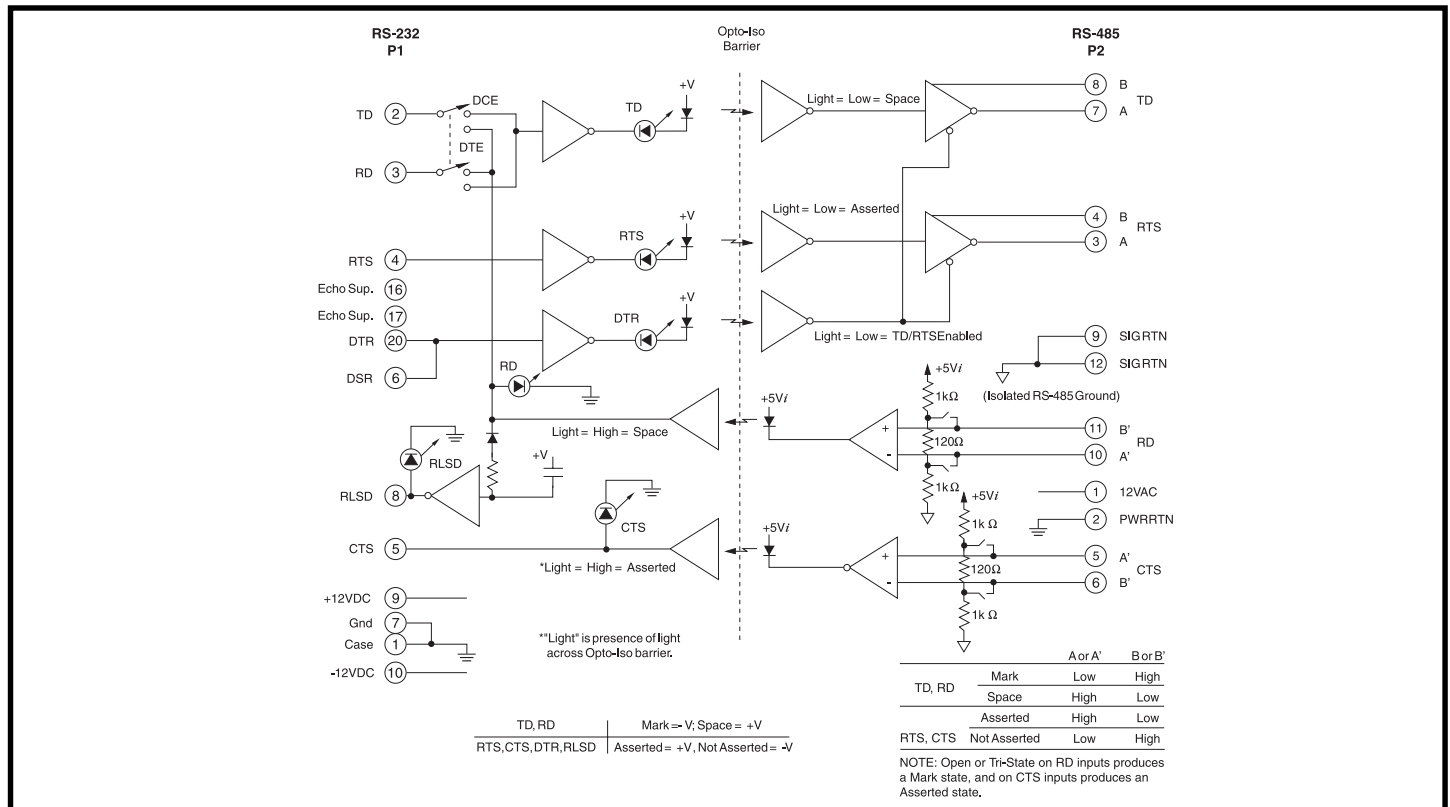

Figure 1: LDM485 Block Diagram

RS-232 Pin Descriptions			RS-422 P2 Pin Desc.		
Pin 1	Case	Case Ground	Pin 1	12VAC	
Pin 2	TD [3]	Transmit Data	Pin 2	PWR RTN	
Pin 3	RD [2]	Receive Data	Pin 3	RTS A	
Pin 4	RTS [7]	Request To Send	Pin 4	RTS B	
Pin 5	CTS [8]	Clear To Send	Pin 5	CTS A'	
Pin 6	DSR [6]	Data Set Ready (connected to Data Terminal Ready)	Pin 6	CTS B'	
Pin 7	GND [5]	Signal Ground	Pin 7	TD A	
Pin 8	RLSD [1]	Receive Line Signal Detect	Pin 8	TD B	
Pin 9	+12VDC	Positive DC Supply Input	Pin 9	SIG RTN	
Pin 10	-12VDC	Negative DC Supply Input	Pin 10	RD A'	
Pin 16	Echo Sup	Echo Suppression (tie to pin 17 to enable)	Pin 11	RD B'	
Pin 17	Echo Sup	Echo Suppression (tie to pin 16 to enable)	Pin 12	SIG RTN	
Pin 20	DTR [4]	Data Terminal Ready (connected to Data Set Ready)			

Pin numbers given are for the 25-pin connector with the 9-pin equivalent in [ ].

### Installation

Installation of the LDM485 consists of attaching it to its mating 25-pin connector on the terminal of the host computer, either directly or through a cable. Optional mounting screws and screw jacks are provided.

The DCE/DTE (data-communication equipment/data terminal equipment) switch must be set to be complementary to the terminal or computer port (DCE connects to DTE and DTE to DCE). Since the LDM485 is a communications device, its normal setting is DCE.

In the event that the host port is not known, the LED indicators may be used to find the proper switch setting. The transmit and receive LEDs will be off during a MARK, which is the normal, or standby, condition when no data is being transmitted. Set the switch to the position which allows these LEDs to be off. The field wiring as shown in Figure 2 must be correct. It is sometimes useful to tie the RS-485 data output back to the RS-485 input during initial check-out.

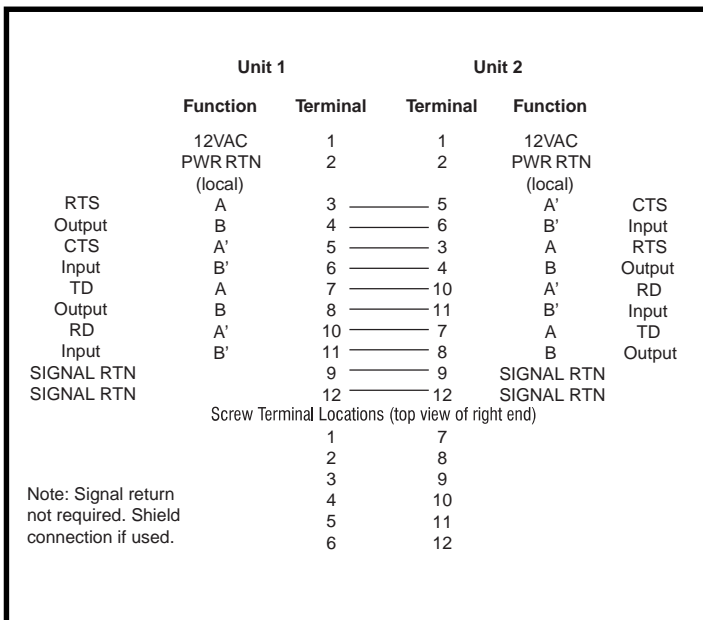

Figure 2: Field Wiring, LDM to LDM

- NOTES:
- (1) For data channels MARK is A negative relative to B.
  - (2) For control lines Assertion is A positive relative to B.
  - (3) RTS = Request To Send, CTS = Clear To Send, TD = Transmitted Data, RD = Received Data.
  - (4) Recommended wire sizes are 14AWG to 22AWG. Belden 8442 or Signal 1172 are typical low cost, nonshielded, twisted pair cables for use with LDM485.
  - (5) Signal return is not required. Cable shield, if used, should be connected to SIGNAL RTN.
  - (6) LDM485 units are suitable for use in RS-422/485 applications.

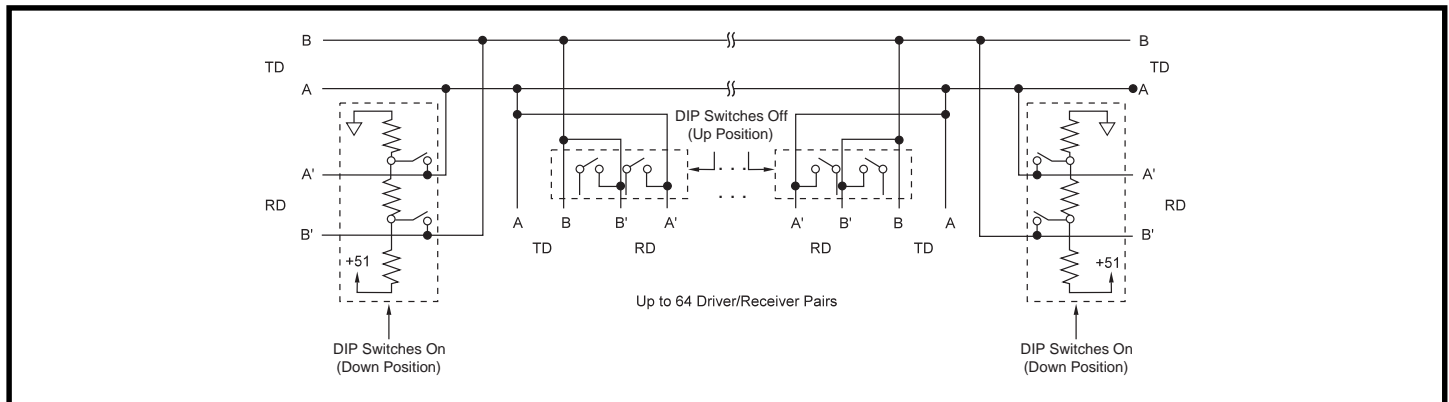

Figure 3: LDM485 Multidrop Wiring Connection

The four other LEDs indicate the status of various control conditions and will be on when these functions are asserted. An open circuit to Request To Send will be interpreted as assertion, allowing convenient operation with equipment not supporting this function. An open circuit on the Receive Data line of the RS-485 circuits will be interpreted as a MARK.

For 2-wire half-duplex and for 2-wire multi-drop installations, echo suppression is available by strapping P1 pin 16 to P1 pin 17. Then RTS asserted enables echo suppression and forces RD (P1 pin 3) to a MARK.

Data Terminal Ready, DTR, must be asserted before the LDM485 can transmit data. This is normally done by the host computer. For situations where the host equipment does not have the capability of supplying a DTR signal, RLSD may be used to continuously assert DTR. On the RS-232 connector P1 of each LDM485, simply connect RLSD pin 8 to DTR pin 20. This connection is not appropriate for multi-drop installations.

For multi-drop installations, the following points should be considered (see Figure 3 for multi-drop wiring connections):

1. If the LDM485 is not powered, it releases the transmit bus so other RS-485 devices may use the bus.
2. Local equipment connected to the RS-232 connector must not leave DTR in the asserted state.
3. An open circuit or zero volts on the RS-232 connector pin 20 (DTR) is equivalent to disassertion.
4. The RS-485 line should be terminated at both ends using internal line termination DIP switches (see Figure 3). Stub length off the main line should be as short as possible.
5. DTR should be asserted at least 5.0µs before start bit and disasserted at end of last stop bit. This disables the RS-485 line after 6.0µs min.

**WARNING!** Because PWR RTN and RS-232 GND (P1-7) and Shield (P1-1) are common, when powering more than one unit from the same transformer, wire all units' 12VAC's together to one side of the secondary and all PWR RTN's together to the other side of the secondary.

**Ordering Information**

Model	Description
LDM485-P	Male RS-232 connector
LDM485-S	Female RS-232 connector
LDM485-PT	Male RS-232 connector and U.S. power transformer
LDM485-ST	Female RS-232 connector and U.S. power transformer
LDM485-PE	Male RS-232 connector, European power transformer
LDM485-SE	Female RS-232 connector, European power transformer
PT3	Wall mount U.S. power transformer, 120VAC
PT3E	Wall mount Euro power transformer, 220VAC

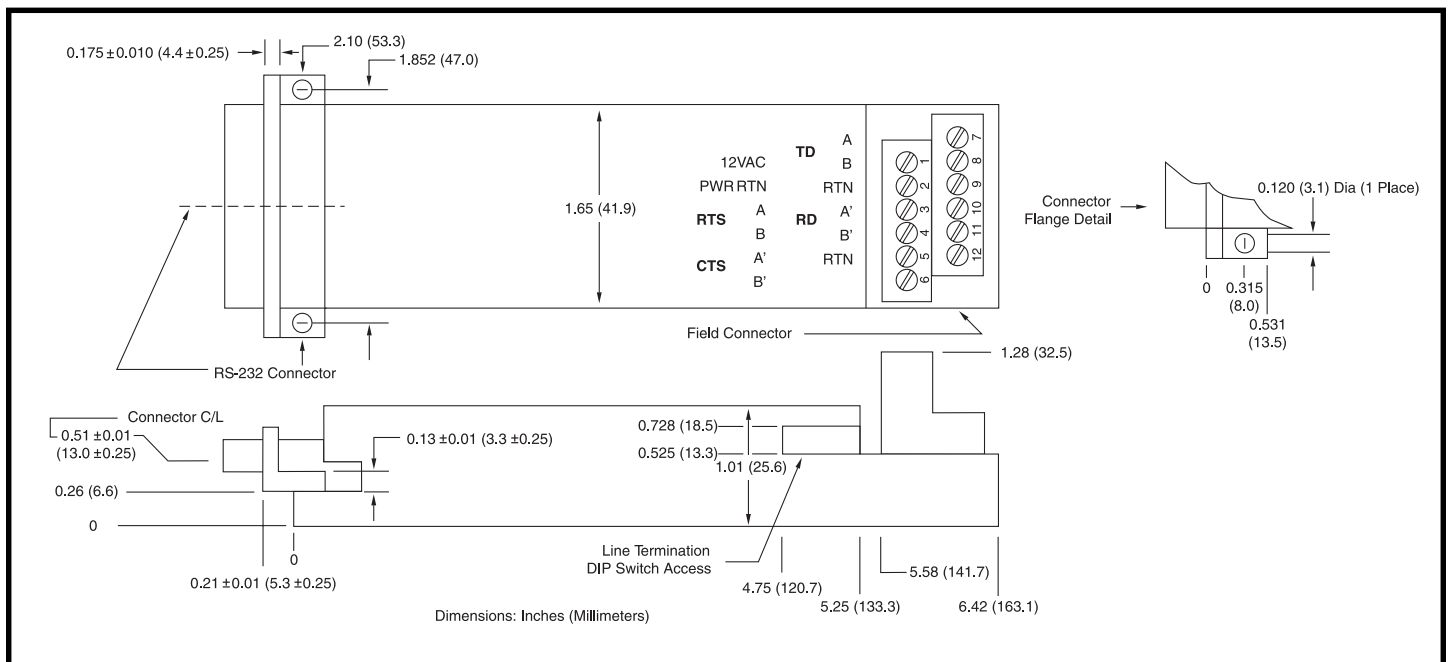

Figure 4: LDM485 Dimensions