



# Analog Input Modules: RTD and Potentiometer

## Interface to 2-Wire, 3-Wire, and 4-Wire Sensors

### Description

Two MAQ20 resistance input modules are offered. One interfaces to 2-wire and 3-wire sensors and has 6 input channels; the other interfaces to 4-wire sensors and has 5 input channels. The 2-wire/3-wire module interfaces to 3 types of sensors: 100Ω Pt and 120Ω Ni RTDs, and potentiometers up to 5kΩ; the 4-wire module interfaces to 100Ω Pt and 120Ω Ni RTDs. Precision, low magnitude current sources are used to minimize sensor self-heating and cancel lead resistance errors when using 3-wire sensors. All channels are individually configurable for sensor, range, alarm limits, and averaging to match the most demanding applications. High, Low, High-High and Low-Low alarms provide essential monitoring and warning functions to ensure optimum process flow and fail-safe applications. Hardware low-pass filtering in each channel provides rejection of 50 and 60Hz line frequencies. Field I/O connections are made through a pluggable terminal block with positions designated for the termination of wiring shields.

Input-to-bus isolation is a robust 1500Vrms and each individual channel is protected up to 240Vrms continuous overload in case of inadvertent wiring errors. Overloaded channels do not adversely affect other channels in the module, which preserves data integrity.

Channels in a module can be selectively enabled for scanning. All channels are enabled by default; however, non-used channels can be disabled to increase the sampling rate of enabled channels.

Input sensors and input ranges are selectable on a per-channel basis. One to three ranges are available depending on the input sensor. Over-range and under-range up to 2% beyond the specified input values is allowed. Sensor linearization is performed in the module, and accuracy is guaranteed to ±f.s.

### Features

- 6 Input Channels for 2-Wire or 3-Wire Sensors
- 5 Input Channels for 4-Wire Sensors
- Interface to Pt100, Ni120 RTDs, and Potentiometers up to 5kΩ
- All Channels Individually Configurable for Sensor, Range, Alarms, Averaging
- 1500Vrms Input-to-Bus Isolation
- Each Channel Protected up to 240Vrms Continuous Overload
- Selective Enabling of Module Channels for Scanning

All MAQ20 modules are designed for installation in Class 1, Division 2 hazardous locations and have a high level of immunity to environmental noise commonly present in heavy industrial environments.

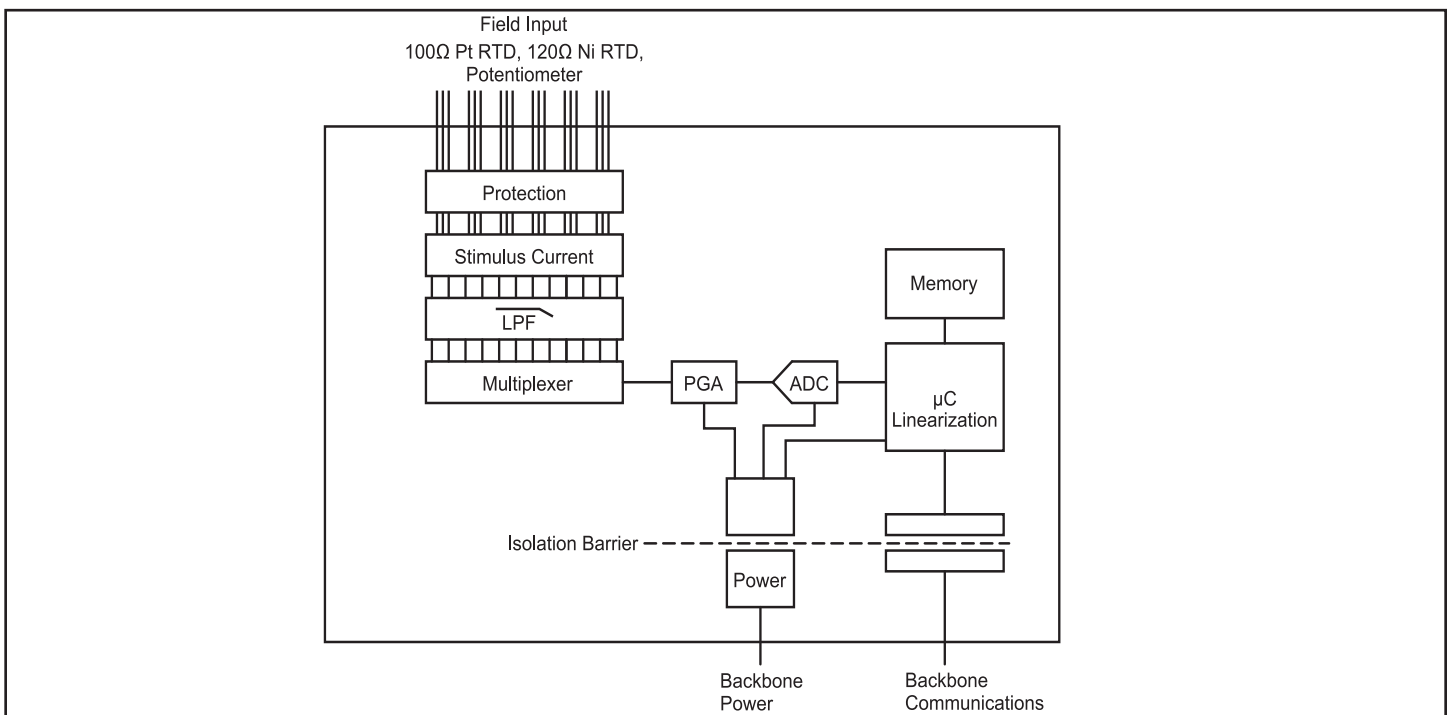

Figure 1: MAQ20-RTD31 RTD and Potentiometer Input Module Block Diagram

**Specifications** Typical\* at T<sub>A</sub> = +25°C and +24VDC system power

Module	Description
MAQ20-RTD31	6-channel, 2-wire or 3-wire Pt100, Ni120, Potentiometer Input 100Ω Pt α = 0.00385; -200°C to +850°C (Default) 100Ω Pt100 α = 0.00385; -200°C to +200°C Pt100 α = 0.00385; -100°C to +100°C Ni120 α = 0.00672; -80°C to +300°C
MAQ20-RTD41	Potentiometer 0Ω to 5kΩ 5-channel, 4-wire Pt100, Ni120 100Ω Pt α = 0.00385; -200°C to +850°C (Default) 100Ω Pt100 α = 0.00385; -200°C to +200°C Pt100 α = 0.00385; -100°C to +100°C Ni120 α = 0.00672; -80°C to +300°C
Per Channel Setup	Individually configurable for sensor, range, alarms, averaging
Input Protection	
Continuous	240Vrms max
Transient	ANSI/IEEE C37.90.1
CMV	
Channel-to-Bus	1500Vrms, 1 min
Channel-to-Channel	±3V peak
Transient	ANSI/IEEE C37.90.1
CMR	100dB at 50/60Hz
NMR	20dB at 50/60Hz
Accuracy <sup>(1)</sup>	±0.06% span
Conformity	±0.035% span
Resolution	0.012% span
Stability	
Zero	±50ppm/°C
Span	±35ppm/°C
Bandwidth, -3dB	3Hz
Scan Rate	200 Ch/s
Alarms	High / High-High / Low / Low-Low
Open Input Response	Upscale or Downscale, 5 s, Flag Set
Power Supply Current	35mA
Dimensions (h)(w)(d)	4.51" x 0.60" x 3.26" (114.6mm x 15.3mm x 82.8mm)
Environmental	
Operating Temperature	-40°C to +85°C
Storage Temperature	-40°C to +85°C
Relative Humidity	0 to 95% Noncondensing
Emissions, EN61000-6-4	ISM Group 1
Radiated, Conducted	Class A
Immunity EN61000-6-2	ISM Group 1
RF	Performance A ±0.5% Span Error
ESD, EFT	Performance B
Certifications	Heavy Industrial CE Compliant UL/CUL Listing Pending (Class I, Division 2, Groups A, B, C, D) ATEX Compliance Pending

## NOTES :

\*Contact factory or your local Dataforth sales office for maximum values.

(1) Includes conformity, hysteresis and repeatability.

**Ordering Information**

Model	Description
MAQ20-RTD31	Analog Input Module; RTD/Potentiometer, 2-Wire or 3-Wire, Type Pt and Ni, 6-ch
MAQ20-RTD41	Analog Input Module; RTD, 4-Wire, Type Pt and Ni, 5-ch

Terminal Block Position (top to bottom)	MAQ20-RTD31 Input Connections
1	CH0 +EXC/SHIELD
2	CH0 +IN
3	CH0 -IN
4	CH1 +EXC/SHIELD
5	CH1 +IN
6	CH1 -IN
7	CH2 +EXC/SHIELD
8	CH2 +IN
9	CH2 -IN
10	NC
11	NC
12	CH3 +EXC/SHIELD
13	CH3 +IN
14	CH3 -IN
15	CH4 +EXC/SHIELD
16	CH4 +IN
17	CH4 -IN
18	CH5 +EXC/SHIELD
19	CH5 +IN
20	CH5 -IN

**For input connections and full details on module operation, refer to MA1044 – MAQ20 RTD-Potentiometer Input Module Hardware User Manual, available for download at: [www.dataforth.com/maq20\\_download.aspx](http://www.dataforth.com/maq20_download.aspx)**