

**Module Dimensions and Pinouts**

The following mechanical drawing is useful when designing circuit boards to mount the 8B modules. Many sockets are available which accept the mounting pins. As an example, Mill-Max provides a socket

with part number [0660](#). The captive nut for the 4-40 mounting screw can be obtained from PEM (Penn Engineering and Manufacturing), part number [KFS2-440](#).

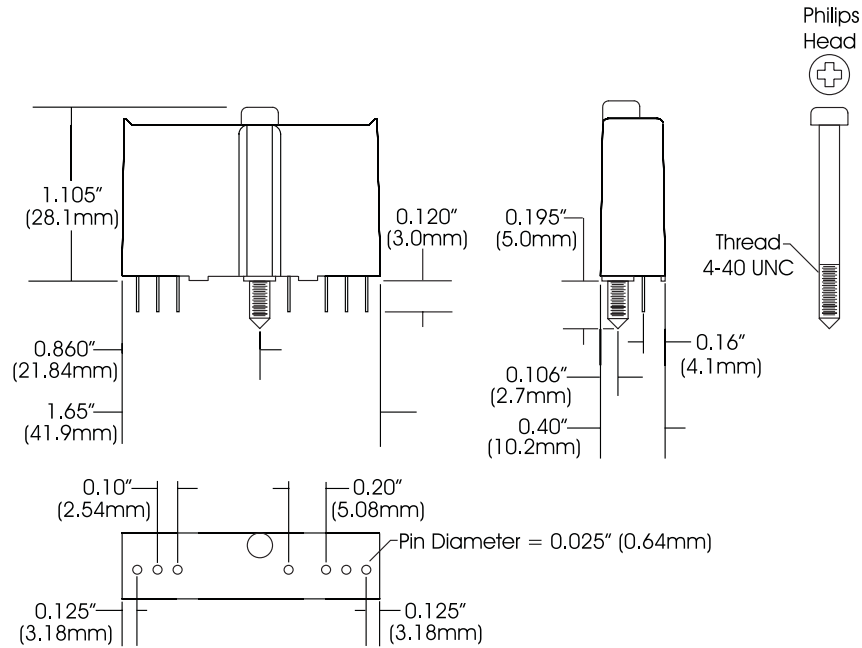

NOTE:  
All dimensions are "Typical" unless otherwise noted.

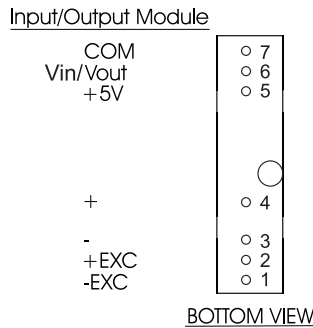

**8B Module Package Drawing Dimensions Typical**