

# DSCT30/31

## Analog Voltage-input Transmitters



### DESCRIPTION

Each DSCT30 and DSCT31 voltage-input transmitter provides a single channel of analog input which is filtered, isolated, amplified, and converted to a process current output (Figure below). Signal filtering is accomplished with a five-pole filter, which provides 85dB of normal-mode rejection at 60Hz and 80dB at 50Hz. An anti-aliasing pole is located on the field side of the isolation barrier, and the other four are on the process loop side. After the initial field-side filtering, the input signal is chopped by a proprietary chopper circuit. Isolation is provided by transformer coupling, again using a proprietary technique to suppress transmission of common-mode spikes or surges.

Special input and output circuits on the DSCT30 and DSCT31 transmitters provide protection against accidental connection of power-line voltages up to 240VAC and against transient events as defined by ANSI/IEEE C37.90.1. Signal and loop power lines are secured to the module using screw terminals, which are in pluggable terminal blocks for ease of system assembly and reconfiguration.

The modules have excellent stability over time and do not require recalibration; however, zero and span settings are adjustable up to  $\pm 10\%$  to accommodate situations where fine-tuning is desired. The adjustments are made using potentiometers located under the front panel label and are non-interactive for ease of use.

### FEATURES

- Accepts Millivolt and Voltage Level Signals
- Process Current Output
- 1500Vrms Transformer Isolation
- ANSI/IEEE C37.90.1 Transient Protection
- Input and Output Protected to 240VAC Continuous
- Up to 60V Loop Voltage
- 160dB CMR
- 85dB NMR at 60Hz, 80dB at 50Hz
- $\pm 0.03\%$  Accuracy
- $\pm 0.01\%$  Linearity
- Easily Mounts on Standard DIN-rail
- CSA C/US Certified
- CE Compliant
- Manufactured per RoHS III Directive 2015/863

### BENEFITS

- High-density Signals Provide Improved Accuracy
- Protects Against Accidental Connection of Power Line Voltages
- Screw Terminal Provide Secure Connections
- More Accurate Representation of Change in Physical Phenomena

### APPLICATIONS

- Data Acquisition
- Test and Measurement
- Control Systems

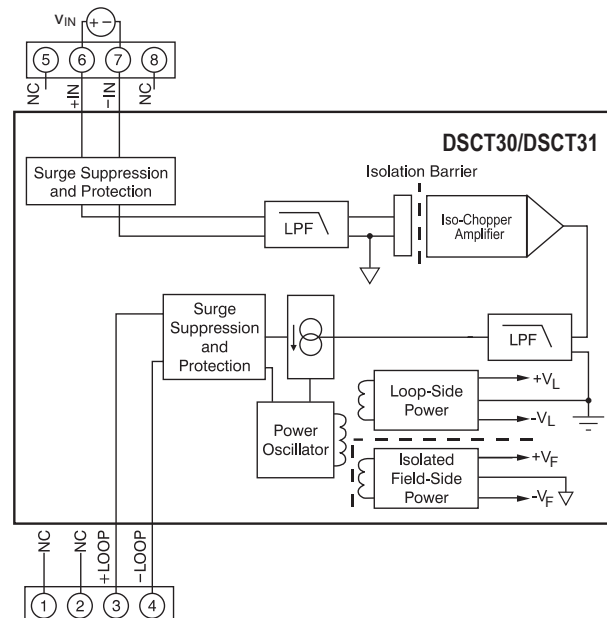

DSCT30/31 Block Diagram - [For Module Dimensions and Pinouts. See Page 7-47](#)

**Specifications** Typical\* at T<sub>A</sub> = +25°C and +24VDC Loop Voltage

Module	DSCT30	DSCT31
Input Range	±10mV to ±100mV	±1V to ±20V
Input Bias Current	±0.5nA	±0.05nA
Input Resistance		
Normal	50MΩ	2MΩ
Power Off	66kΩ	2MΩ
Overload	66kΩ	2MΩ
Input Protection		
Continuous	240Vrms (max)	240Vrms (max)
Transient	ANSI/IEEE C37.90.1	ANSI/IEEE C37.90.1
CMV, Input to Output		
Continuous	1500Vrms (max)	1500Vrms (max)
Transient	ANSI/IEEE C37.90.1	ANSI/IEEE C37.90.1
CMR (50Hz or 60Hz)	160dB	160dB
NMR	85dB at 60Hz, 80dB at 50Hz	85dB at 60Hz, 80dB at 50Hz
Adjustability	±10% Zero and Span	±10% Zero and Span
Accuracy <sup>(1)</sup>	±0.03%	±0.03%
Conformity	±0.01%	±0.01%
Stability		
Offset	±20ppm/°C	±20ppm/°C
Gain	±80ppm/°C	±80ppm/°C
Noise		
Output, 100kHz	3μArms	3μArms
Bandwidth, -3dB	3Hz	3Hz
Response Time, 90% Span	165ms	165ms
Output Range	4-20mA	4-20mA
Output Limits		
Under-range	2.8mA	2.8mA
Over-range	29mA	29mA
Output Protection		
Reverse Polarity	Continuous	Continuous
Over-voltage	240Vrms Continuous	240Vrms Continuous
Transient	ANSI/IEEE C37.90.1	ANSI/IEEE C37.90.1
Loop Supply Voltage	10.8V to 60V	10.8V to 60V
Loop Supply Sensitivity	±0.0005%/V	±0.0005%/V
Turn-on Delay	400ms	400ms
Mechanical Dimensions (h)(w)(d)	2.95" x 0.89" x 4.13" (75mm x 22.5mm x 105mm)	2.95" x 0.89" x 4.13" (75mm x 22.5mm x 105mm)
Mounting	DIN EN 50022 -35x7.5 or -35x15 Rail	DIN EN 50022 -35x7.5 or -35x15 Rail
Environmental		
Operating Temperature	-40°C to +80°C	-40°C to +80°C
Storage Temperature	-40°C to +80°C	-40°C to +80°C
Relative Humidity	0 to 95% Noncondensing	0 to 95% Noncondensing
Emissions, EN61000-6-4	ISM, Group 1	ISM, Group 1
Radiated, Conducted	Class A	Class A
Immunity EN61000-6-2	ISM, Group 1	ISM, Group 1
RF	Performance A ±0.5% Span Error	Performance A ±0.5% Span Error
ESD, EFT	Performance B	Performance B

**NOTES:**

\*Contact factory or your local Dataforth sales office for maximum values.

(1) Includes linearity, hysteresis, and repeatability.

**Ordering Information**

Model	Input Range
DSCT30-01	-10mV to +10mV
DSCT30-02	-50mV to +50mV
DSCT30-03	-100mV to +100mV
DSCT30-04	0mV to +10mV
DSCT30-05	0mV to +50mV
DSCT30-06	0mV to +100mV
DSCT31-01	-1V to +1V
DSCT31-02	-5V to +5V
DSCT31-03	-10V to +10V
DSCT31-04	0V to +1V
DSCT31-05	0V to +5V
DSCT31-06	0V to +10V
DSCT31-07	-20V to +20V
DSCT31-08	0V to +20V