

What Is Redundant Data Acquisition? (And Why Would You Want It?)

As anyone who works with computers well knows, systems crash, data gets lost, and endless hours are spent trying to recover. Yet, this situation is easily avoidable using redundant data acquisition methods. When we analyze a typical application from input to output, we can see or imagine a chain of functional events where each link in the chain may be an opportunity for a “single point of failure.” From this analysis, we can divide each event or functional section down and decide the degree of protection, backup, or redundancy appropriate for that point. Of course, this analysis would weigh in the financial impact of downtime – how much lost production costs per hour, how much it might cost to repair a failed point, etc. Depending on the application, you might elect to install a simple UPS (uninterruptible power supply) to provide backup power or you might elect to duplicate the entire system. Fortunately, there are other options between these extreme cases.

There are at least five basic ways to provide redundancy in a data acquisition system. By combining these different redundancy methods, many hybrid systems can be created. The table below lists the basic types.

Basic Redundancy Types

Type	Redundant:	Provides for:	Dataforth isoLynx® Selection
1	Power Supply	Basic power backup	SLX200-any
2	Data Path	Backup data path	SLX200-30
3	Network Node	Path around single failed switch	SLX200-30
4	Network	Path around multiple failed switches	SLX200-30
5	Complete System	Path around failed system	SLX200-30

Dataforth's isoLynx® SLX200 is an industrial data acquisition system that can be applied across all types of redundant configurations.

The SLX200-30 is the dual-Ethernet model of the isoLynx® SLX200 family. It offers two independent, 10Base-T Ethernet ports, each of which implements the industry standard Modbus TCP protocol. Simultaneous communication with both Ethernet ports is supported, and each Ethernet port supports up to four socket connections at TCP port 502. Each socket is capable of servicing up to four Modbus TCP commands at a time. In addition, users can configure each 10Base-T port with individual socket keepalive timeouts (the default is configured with a timeout of two hours).

In addition to the protections provided by redundancy, isoLynx® SLX200 hardware and the SCM5B signal conditioning modules used with the SLX200 data acquisition system exceed 500,000 hours MTTF (mean time to failure). The hardware is manufactured in Tucson, AZ (USA)

under a certified ISO9001:2000 Quality Management System and each element exceeds Six Sigma reliability.

A free SLX configuration software utility, provided with the SLX200, can be used to configure Ethernet port communication parameters such as the IP Address and Subnet Mask. The default values for both ports are as follows:

Primary Port: IP Address: 192.168.0.215
 Subnet Mask: 255.255.255.0

Secondary Port: IP Address: 192.168.0.216
 Subnet Mask: 255.255.255.0

Graphic illustrations of the five basic redundancy types are below.

Type 1: Redundant Power Supply (Uninterruptible Power Supply or Other Device)

This automatically provides backup power and could be used as a minimum layer of system protection.

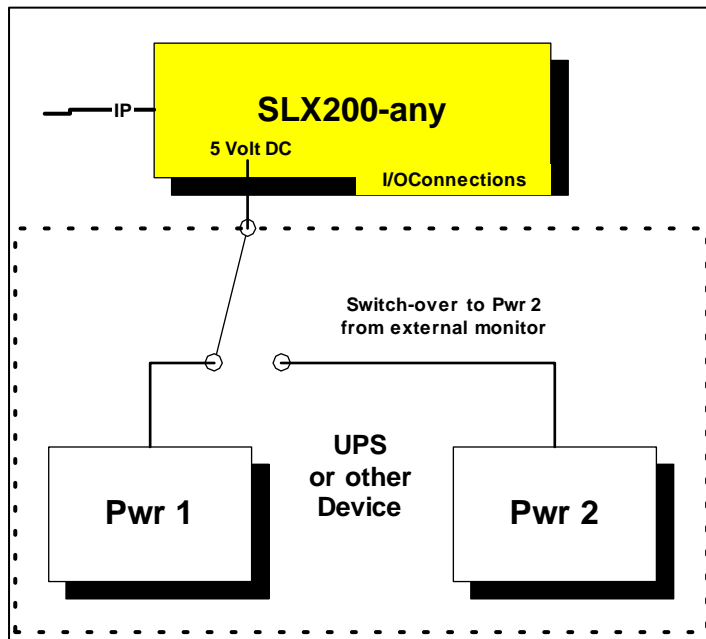

Type 2: Redundant Data Path

This provides a secondary route for device information.

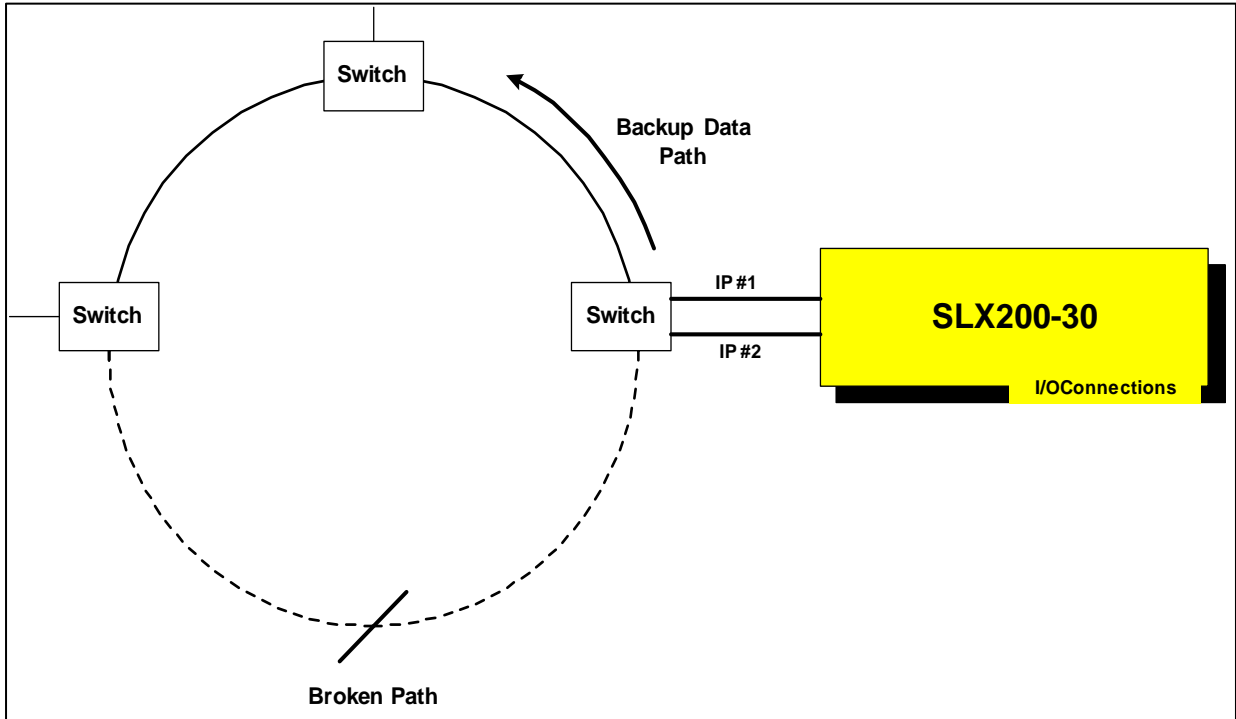

Type 3. Redundant Network Switch(es) or Node(s)

These provide a secondary route for failed switches.

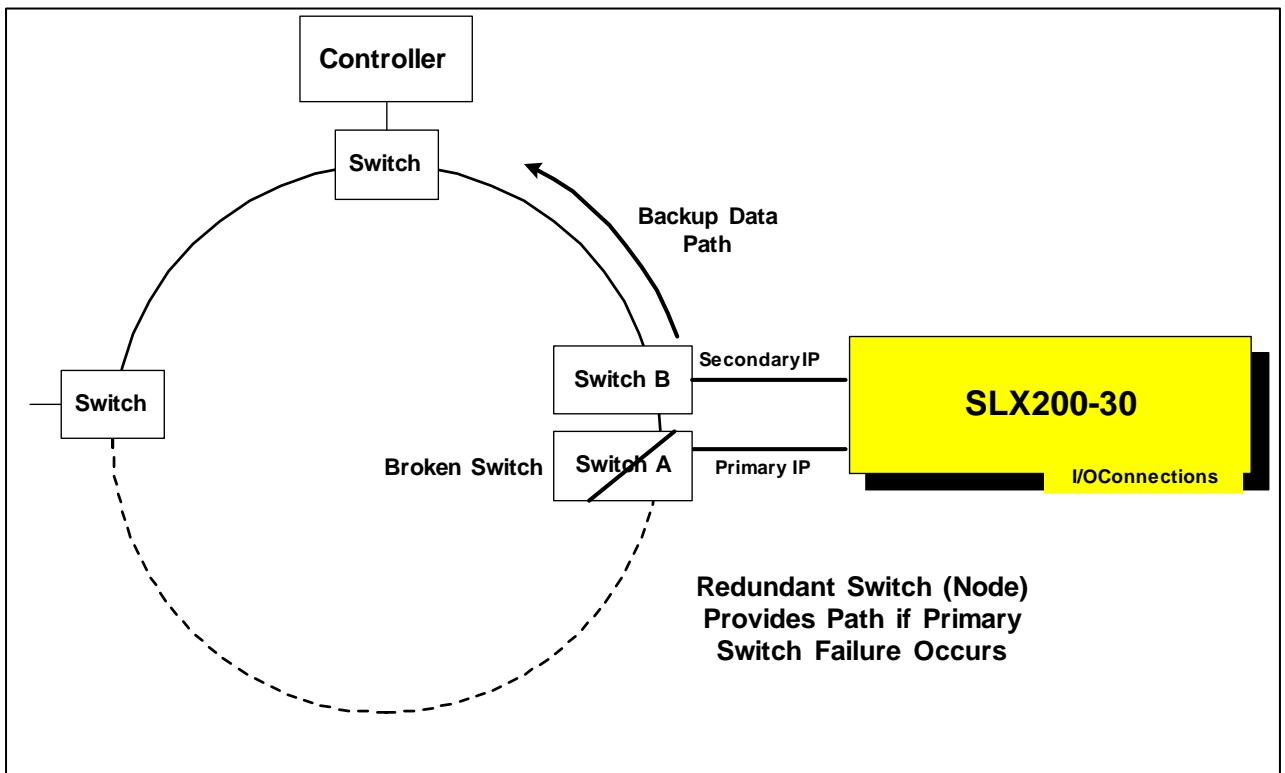

Type 4: Redundant Network

This provides backup for a failed network.

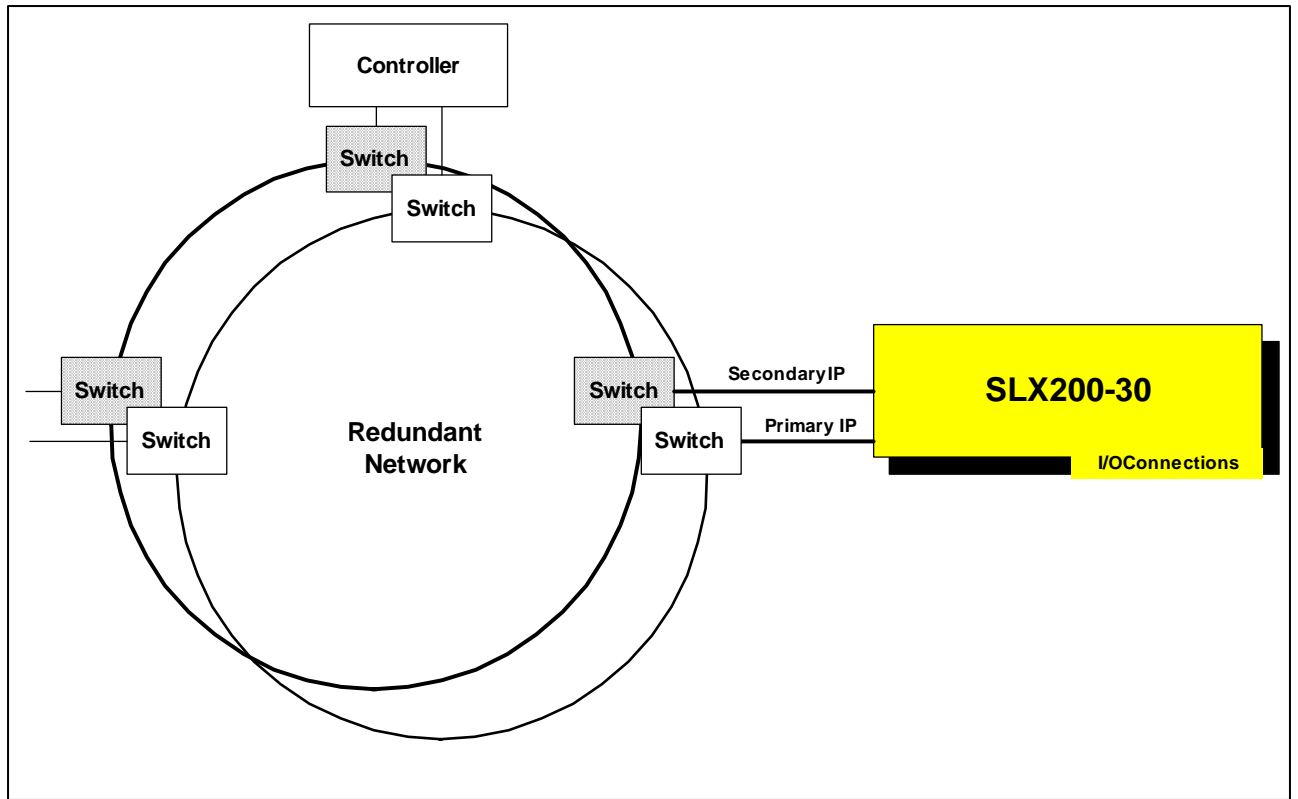

Type 5. Redundant System

This completely duplicates all elements of the system, including the Controller and I/O.

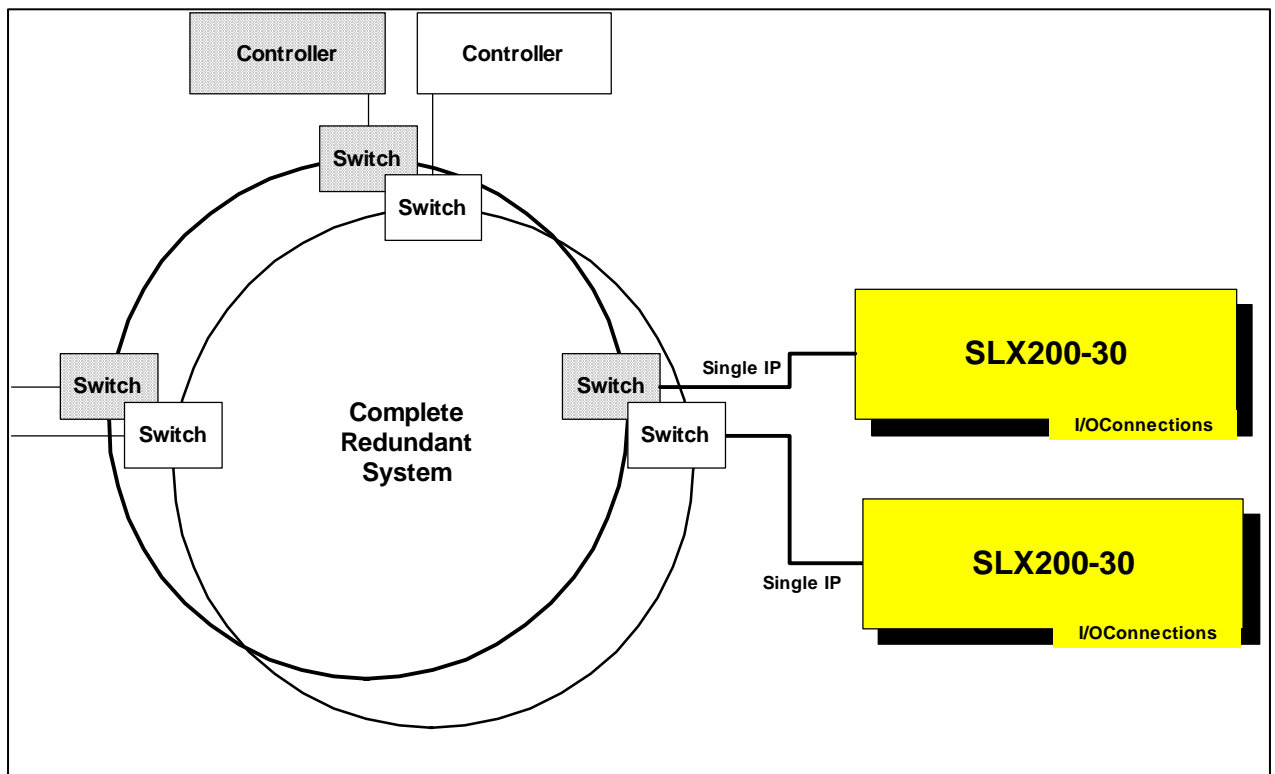

As shown in these graphics, it is no longer necessary to spend time searching for lost data as simple yet very effective methods of redundant data acquisition are readily available. Dataforth's isoLynx® SLX200-30 is a highly efficient redundant Ethernet data acquisition system that is usable across all types of redundant configurations.

For more information and technical specifications of Dataforth's isoLynx® SLX200 family, please visit <http://dataforth.com/catalog/pdf/slx200.pdf>.